

R 410A	0	1730	< 0.2	72.6	-51	72	49.5
--------	---	------	-------	------	-----	----	------

9.8.2 REFRIGERATION COMPRESSORS

In refrigeration systems, displacement or dynamic compressors are used depending on the case, sections 4.2 and 4.3 of Part 2 being respectively dedicated to them; readers interested in further developments on this matter should refer to them. We just give here some details on specific refrigeration features.

In addition to piston, screw and centrifugal compressors, there is a fourth type of compressor that is widespread in refrigeration: spiral or scroll compressors (Figures 9.8.1 to 9.8.3) whose operating characteristics are close to screw machines (existence of a constructive V_i and losses by over- or under-compression if the compression ratio deviates from the actual constructive value, cf. section 4.2.2 of Part 2).

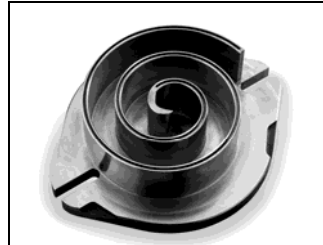

Figure 9.8.1: Scroll spiral, Documentation Maneurop

In this type of compressor, two cylindrical spirals, one fixed and one mobile (Figure 9.8.2) identically shaped, roll by sliding one on another, locking gas pockets of variable volume, which provides compression. The gas is sucked at the circumference and discharged in the center.

The advantages of this device are the lack of valves, the simple mechanism and hence its low cost and its silence, low mechanical losses, the possibility to rotate at high speeds, lack of vibration, light weight, reliability and low torque.

Technological problems are mainly in the machining of spirals and the seal between each spiral and the bottom of its conjugate. These compressors can operate without oil.

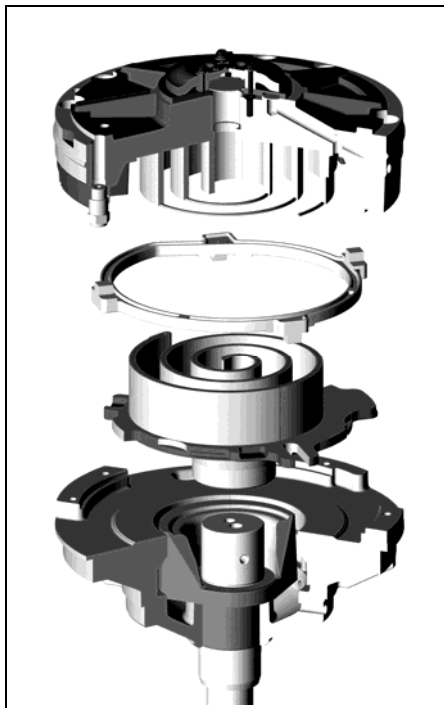

Figure 9.8.2: Cutaway of a scroll compressor , Documentation Maneurop

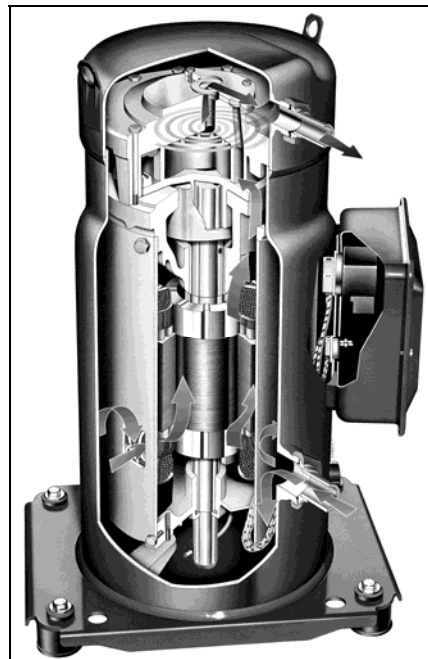

Figure 9.8.3: Scroll compressor cutaway, Documentation Maneurop

We can classify refrigeration compressors in three broad categories:

- open compressors (Figure 9.8.4) are manufactured in a frame independent of the motor, which is therefore outside. This provision, usually reserved for high-capacity machines, facilitates the maintenance of the compressor or the engine, but requires a good seal at the shaft that connects them, otherwise air inlets or refrigerant leakage can be expected;

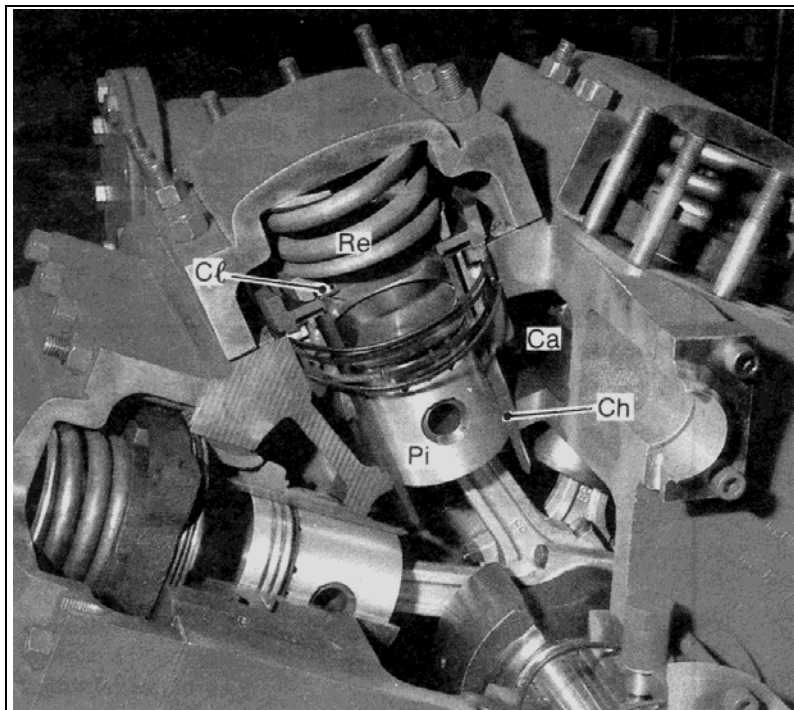

Figure 9.8.4: Cutaway of a piston compressor, *Extrait de Techniques de l'Ingénieur, Génie Energétique*

- in hermetic compressors instead (Figures 9.8.3 and 9.8.7), the motor and compressor both bathe in the fluid vapor. It is then possible to enclose everything in a single housing, thereby ensuring a perfect seal. The disadvantage is that the whole is not removable and that on-site maintenance is impossible. The electric motor is typically an induction one and the fluid must be an electrical insulator. This type of configuration is restricted to low capacities (75-500 W), the compressor being as appropriate piston or rotary;
- accessible hermetic compressors (Figure 9.8.5) have the same advantages in terms of hermetic sealing, but with the added opportunity to intervene on site. They are reserved for intermediate capacity ranges (500 W - 500 kW).

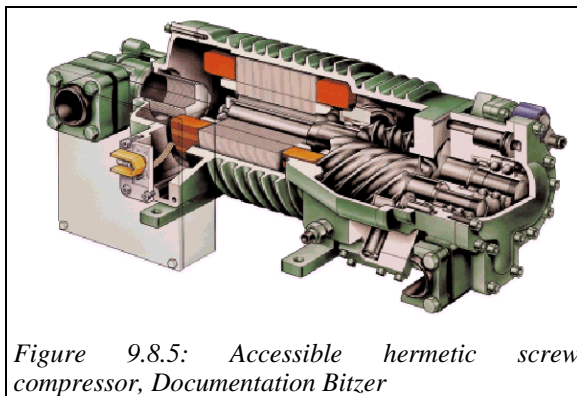

Figure 9.8.5: Accessible hermetic screw compressor, *Documentation Bitzer*

Note finally that it is better (and regulatory beyond a certain capacity) to provide a protective device for reciprocating compressors in case of liquid suction, which may take place if

superheating at the evaporator outlet is incorrectly set (this is called a liquid stroke). The solution generally adopted is to provide a bolt, pressed against the cylinder by a spring of high stiffness (such as that noted Re in Figure 9.8.4).

In normal operation, the set remains closed, and in case of liquid stroke, the head is raised and the cylinder is placed in communication with the discharge.

Compressors are often mounted in tandem, either to achieve high compression ratios, or to allow a better adaptation to a load variable over time (Figure 9.8.6).

As a guide, here are some dimensional values of industrial chillers: a 100 kWe ammonia open piston compressor machine has a length of 3.7 m, a width of 1.75 m, a height of 1.7 m and a mass of 4.3 tons empty, and a 300 kWe ammonia screw compressor machine is 3.9 m long, 1.7 m wide, 2.3 m high, its mass being 9 t (York Corporation).

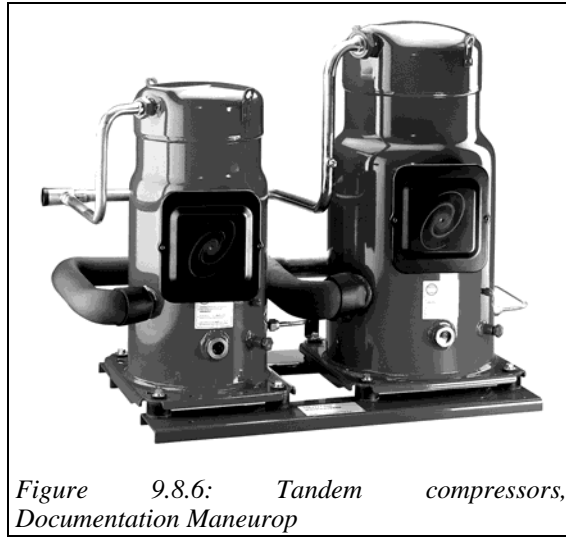

Figure 9.8.6: Tandem compressors, Documentation Maneurop