

Guidance page for practical work 21: Extraction of noncondensable gases from a condenser of a steam propulsion engine of the Merchant Marine (question)

1) Objectives of the practical work

Given its properties, we know that water is an excellent thermodynamic fluid for steam engine cycles, with its critical temperature of 374 °C and its high latent heat of vaporization at ambient pressure and temperature. Its low viscosity allows to limit the consumption of auxiliaries and its low cost and non-toxicity finish to place it in a good position relative to its competitors.

Water does not, however, have only benefits: the condensation temperatures of 20 to 30 °C implies that we maintain a low vacuum in the condenser (a few hundredths of a bar), which implies a device for extracting the noncondensable gases due to leakages of the circuit, which result in inevitable air intakes.

Moreover water contains always different dissolved gases, especially carbon dioxide and oxygen very corrosive to the boiler and return lines. To eliminate them, we use a deaerator, but they cannot be extracted completely.

In addition to its impact on raising the pressure in the condenser, the presence of air or noncondensable gases has the effect of limiting the exchange coefficients by forming a film that opposes the heat transfer and to increase the condensation temperature for a given temperature of the coolant.

The noncondensable extraction devices are generally of two types: either vacuum pumps, for example of the liquid ring type, or battery of ejectors in series.

The objective of this work is to study the use of such ejectors to extract noncondensable gases from the condenser of a steam propulsion engine of the Merchant Marine, to understand the mechanisms that come into play and to estimate the impact of this consumption on the energy balance of the ship.

2) Presentation of an ejector

An ejector (figure 1) receives as input two fluids normally gaseous but which may also be liquid or two-phase (Chunnanond, 2004):

- the high pressure fluid called primary fluid or motive;
- the low pressure fluid, called secondary fluid or aspirated.

The primary fluid is accelerated in a converging-diverging nozzle, creating a pressure drop in the mixing chamber, which has the effect of drawing the secondary fluid. The two fluids are then mixed and a shock wave may take place in the following zone (throat in Figure 4.9.6). This results in an increase in pressure of the mixture and reduction of its velocity which becomes subsonic. The diffuser then converts the residual velocity into increased pressure.

The ejector thus achieves a compression of the secondary fluid at the expense of a decrease in enthalpy of the primary fluid.

We have established an ejector model¹ that was implemented in a Thermoptim external class, to simulate different types of cycles, including refrigeration, involving that component.

¹ <http://www.thermoptim.org/sections/logiciels/thermoptim/modelotheque/modele-ejecteur>

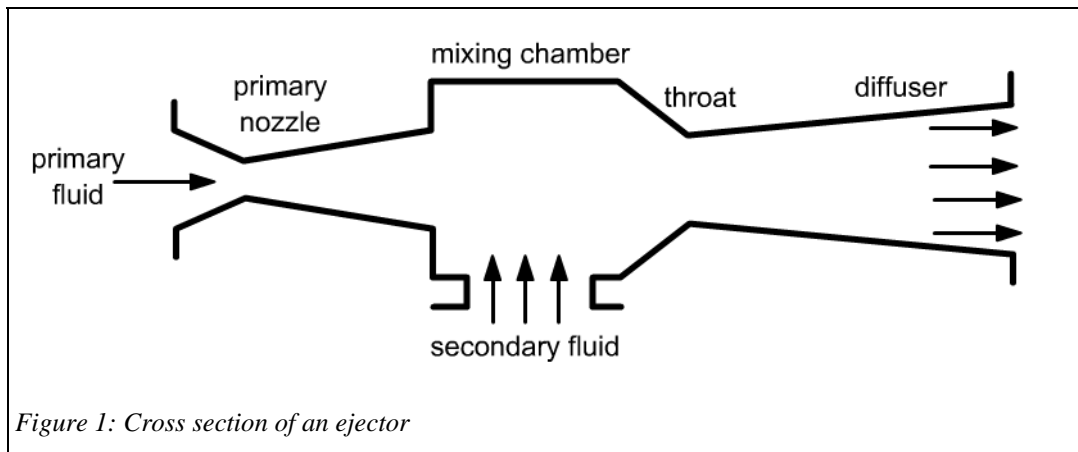

Figure 1: Cross section of an ejector

3) References

D.W. SUN, I.W. EAMES, *Performance characteristics of HCFC-123 ejector refrigeration cycle*, Int. J. Energy Res. 20 (1996) 871–885.

A.A. KORNHAUSER, *The use of an ejector as a refrigerant expander*. Proceedings of the 1990 USNC/IIR—Purdue refrigeration conference, Purdue University, West Lafayette, IN, USA, 1990, p. 10–19.

D. LI, A. GROLL, *Transcritical CO₂ refrigeration cycle with ejector-expansion device*, International Journal of Refrigeration 28 (2005) 766–773

4) Main practical work

4.1 Question

Figure 2 shows the block diagram of a steam cycle with ejectors for extracting air.

- noncondensable gases are sucked in a cold zone of the main condenser, under pressure of 0.05 bar. They are the aspirated flow of the first ejector. Their speed, denoted by m_3 , is the order of 0.023% of the main flow m_1 ;
- at the boiler output, a first extraction is made on the main flow m_1 to form the motive flow of the first ejector. Its flow-rate, denoted by m_2 , is the order of 0.16% of m_1 ;
- the mixed flow exits the first ejector at a pressure of 0.25 bar. It is then condensed by exchange with the water leaving the extraction pump, which it warms slightly. A first separator is used to return condensate to the condenser and the vapor, consisting primarily of non-condensable gases, is the aspirated flow of the second ejector;
- a second extraction at the boiler output is performed on the main flow m_1 to form the motive flow of the first ejector. Its flow-rate, denoted by m_4 is the same order of magnitude as m_2 ;
- the mixed flow exits the second ejector at a pressure slightly above 1 bar. It is also condensed by exchange with the feedwater of the boiler, which it warms slightly. A second separator is used to return the condensate in a deaerator located at the condenser outlet (Note: in Figure 2, the return is given as input to the condenser so as not to complicate the picture), and the vapor, consisting essentially of noncondensable gases is discharged through the vent.

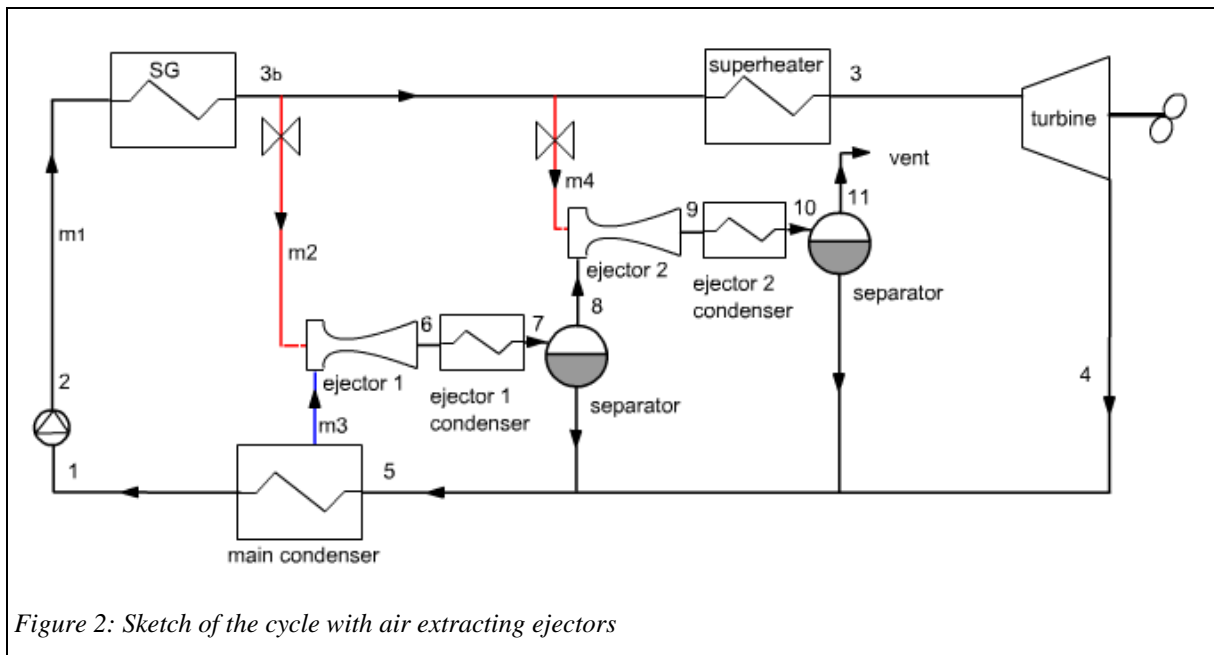

The objective of the work is to build a model of such a cycle in ThermoOptim. For this it is necessary to make some assumptions:

- First, the noncondensable gases will be represented by water vapor. This assumption is necessary because ThermoOptim does not have the libraries enabling it to calculate the thermodynamic properties of a mixture between water vapor and air. In any case, the error induced on the flow of motive steam required is certainly low. However, the temperature of the air leaving the condenser ejector will necessarily be greater than or equal to the saturation water pressure considered, leading to a significant difference with reality. This constraint imposes a different effect: The separators at the outlet of ejectors will simply be modeled as the divider for transmitting the flow of noncondensable gases either to the other ejector, or to the vent, followed for the part corresponding to the steam by a condenser connected to the condenser;
- Given this assumption, we assume that the flow of noncondensable gases is always equal to m_3 , which will require to manually propagate the value in the process corresponding to the aspirated flow of the two ejectors and to the vent in the last separator;
- We may consider, to balance the flows of the cycle, a noncondensable gases inlet (as water) in the deaerator at a rate equal to m_3 ;
- We assume the output pressure of the first ejector known and equal to 0.25 bar. In practice, the return of water to the condenser at the outlet of the first separator is done by putting the latter in slight excess gauge pressure (2 m), which induces a pressure difference of 0.2 bar with the main condenser;
- extractions required to provide the ejector motive flows are made at the outlet of the vaporizer and before superheating. The steam is expanded at 18 bar before entering the ejector;
- the steam propulsion cycle for a ship of the Merchant Marine having a capacity of 31.4 MW will be modeled simply, without representing the turbine generator or the boiler, and simplifying the deaerator (the aim here is to focus on air extraction from the condenser, not to address the full cycle). Consider a flow m_1 equal to 27 kg/s, and boiler outlet conditions 510 °C and 61.8 bar, the turbine outlet enthalpy being equal to 2299 kJ/kg.

Once the cycle set, students are asked to estimate the impact of the ejectors on the energy balance of the ship.

4.2 Diagram of the cycle

Figure 3 shows a possible ThermoOptim diagram for the cycle studied.

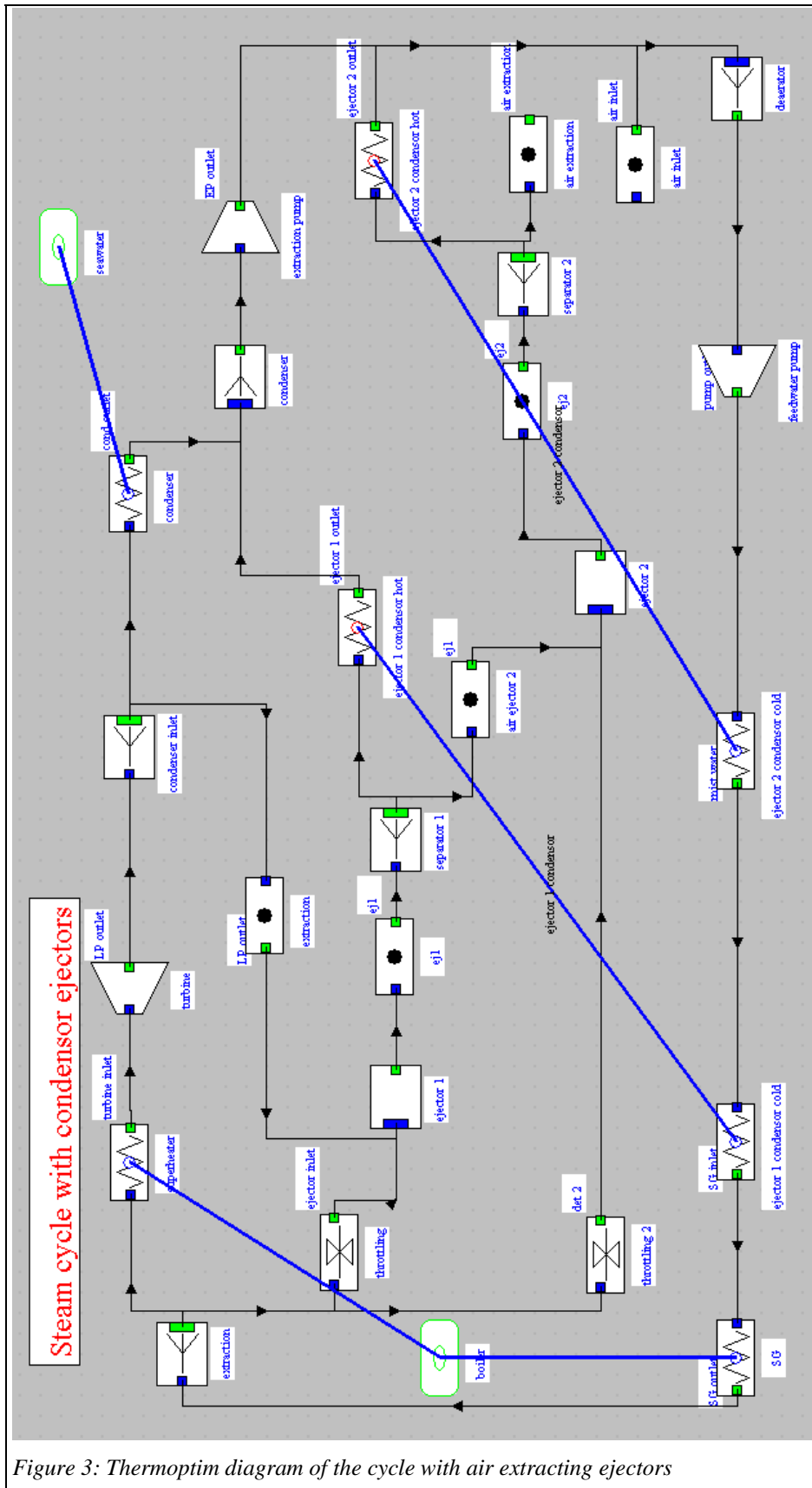

Figure 3: ThermoOptim diagram of the cycle with air extracting ejectors

4.3 Setting of the first ejector

Note that the ejector model is quite sensitive to the different parameters that appear on the screen (Figure 4), which are, let us remember:

- The factor P_e/P_b of pressure drop at the entrance of the secondary fluid in the ejector, which determines the minimum pressure in the ejector
- The isentropic efficiency of the two nozzles (motive and aspirated fluids)
- The isentropic efficiency of the exit diffuser
- The friction factor to take into account a possible pressure drop in the mixing zone.

Figure 4 shows a possible setting for the first ejector: the factor P_e/P_b is 0.96, the two isentropic efficiencies are equal to 0.9, and the friction factor is 0.97. Sensitivity studies may be conducted on the influence of these parameters on the results.

4.4 Limitations of the model

The model thus developed leads to an estimate of the temperature of air discharged close to 150 °C, whereas it is about 65 °C in reality. As we indicated in section presenting the assumptions, this error is related to the inability to sufficiently cool the air without condensing when it is modeled by the water vapor.

Moreover the simplification of the deaerator that has been deliberately made has the effect of increasing compared to the real the flow of water used to cool the condensers of ejectors. Therefore the heating of water in these exchangers is limited to about 2 °C, whereas it should be higher.

4.5 Details of noncondensable gas entries

Although it is difficult to identify precisely where the condensable appear in the water system, the following phenomena can be considered:

- Return water of the blowdown circuit is certainly a primary source. It contains dissolved air which is released into the deaerator to be partially extracted in the unit;
- After a chemical treatment, there is no more oxygen dissolved in water supply, but each molecule of O_2 neutralized released two molecules of N_2 . Subsequently, in contact with the hot metal of the superheater tubes, there is dissociation of water molecules. Oxygen corrodes pipes, leaving hydrogen be aspirated by steam. This reaction, though little developed, plays an active role in the facility aging;
- Other air intakes are generally in the sealed turbine boxes, as well as vacuum blowdown flanges (LPT stages) and the trim valves and vacuum pumps (extraction pumps, suction valves, blowdown valves, etc.). These air entries come directly in the condenser.

5) Work files

The extUser2.zip file is in archive CondensorEjector.zip